

2017-2021

Skylark Restoration



David Williams

10/17/2021

Skylark Restoration

Purchased 12/09/2017.
Ensign 23 built by Stourport Boats
Year Late 1970's early 1980's
Length 23 feet
Beam 6 feet 10 inches
Draft 1 feet 6 inches
Hull Fibre Glass.
Power Honda BF 9.9A outboard (10HP).
(1 to 1.5 litres fuel per hour approx.)
Canal & River Trust number 104032



Moved to Market Drayton 14/09/2017.



Skylark Restoration



Caroline polishing the front screen. 1st with 1000 grade wet & dry, 2nd stage with 2500 grade wet & dry and finally with Jewellers Rouge by hand and machine Mop. 20/09/2017



Skylark Restoration



Caroline putting the finishing touches to the front screen curtain 27/09/2017



Skylark Restoration



Obscure window film fitted to toilet window.



A happy captain!

Skylark Restoration



Beneath the cockpit decking mixture of rotten wood and pallet wood.



Fresh water pump removed as a missing fitting was leaking. Will order and fit new pump.

Skylark Restoration



A bit more rot. All this will come out and new go in.



Skylark Restoration



Although the bulkhead between Cockpit and Cabin looks OK in photos the plywood is delaminating. Basically not water tight or structurally sound.



Skylark Restoration



This is the bulkhead between Cockpit and rear storage area. Bottom totally rotted out.

Even the replacement wood is rotting.



Skylark Restoration



Wiring whilst working, not in reliable state. Bilge pump was discovered to not be pumping water out of boat but recirculating! Now fixed temporarily.



Skylark Restoration



Plywood floor in storage area was hiding two previous rotten floors and their vinyl covering.



Skylark Restoration



09/10/2017



Skylark Restoration



Skylark Restoration



Skylark Restoration



Skylark Restoration



All old bilge water removed by sponging out. Bilge pipe reconnector to external fitting. All rubbish and loose material removed from below deck in cockpit and storage area. 09/10/2017



Skylark Restoration



Patched up wood frames and when trying to remove to act as template all the plywood had rotted between the fiberglass. 27/10/2017



Skylark Restoration



Even the rear bulkhead fell apart when removing.



Skylark Restoration



Most of the removed deck and framework.
And below all I could salvage to form a half template. 27/10/2017



Skylark Restoration



Stringers (floor joists) beginning to take shape. Made from WBP 12mm hardwood ply. To be coated in resin and the Cockpit to Cabin coated in resin and fiberglass matting prior to glassing into the hull.

01/11/2017 Below is the second dry fitting to check the fit of the hull. Cockpit to Cabin bulkhead now needs to be fitted before height of middle and rear stringers can be determined. 02/11/2017



Skylark Restoration



Tidying up the rear of the hull.



Skylark Restoration



Front left quarter scrubbed clean. Below rear scrubbed clean.
Even the petrol tank got a clean. 03/11/2017



Skylark Restoration



Painting the floor prior to fitting the new stringers.
Removed old fibreglass tabs at the stern. 9/11/2017



Skylark Restoration



Starting to sand the cabin wall. 10/11/2017



Planning on making stable style door. New Brass fittings etc.

Skylark Restoration



Three new plywood stringers coated with resin, curing in my make shift oven. 14/11/17. Heated with fan heater and oil filled radiator. Even with these heaters, I could only maintain 18 degrees at a max. This is the minimum temperature to cure the resin. Should harden in 30 minutes. Taking hours! 15/11/17



Skylark Restoration



The Cockpit to Cabin stringer not only coated in resin but has a layer of fiberglass bonded to the exterior (cockpit side). This will be glassed to the hull forming a water proof barrier. 16/11/17

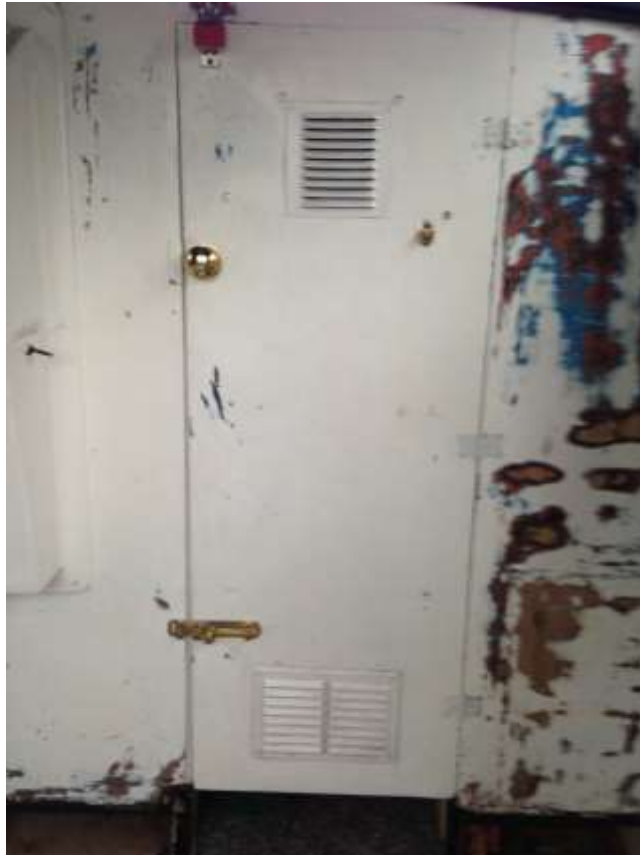

Picture of door gives me better idea for remaking it into stable door.

Skylark Restoration



Floor supports and stringers ready for fitting into boat. 29/11/2017



Skylark Restoration



Floor stringers and supports on the canal bank. Below cabin stringer/wall fitted and bonded in forming a water tight bulkhead. 30/11/2017



Skylark Restoration



Last temporary fitting of the stringers and floor supports. 30/11/2017



Need to trim the stringers height down slightly before final fix. 30/11/2017

Skylark Restoration



New stringers and floor supports installed in Skylark 03/12/2017.
New plywood Floor installed temporarily for boat use over Xmas. 19/12/2017



Skylark Restoration



Started to prototype rear seat/box/gas locker. 5/2/2018.

Final coat of varnish on the side floor panels. 12/2/2018.



Skylark Restoration



Having painted the edges black and pre-cut the EVA sheeting.
These sheets have been stuck down 28/02/2018



Skylark Restoration



Having masked the finished surface of the EVA sheeting a bead of black sealant is applied around the edge to prevent ingress of water. 4/03/2018



Skylark Restoration



New wooden box for new switch panel to be fitted inside cabin. 1/03/2018
Used some scrap plywood to make mug holder for the cockpit. 3/03/2018



Skylark Restoration



New hatch in the centre floor panel 7/3/2018
First trial fitting of Seat/step/gas locker 6/3/2018



Skylark Restoration



Fitted Yamaha 703 remote control.
Need to convert from push to pull 6/3/2018



Skylark Restoration

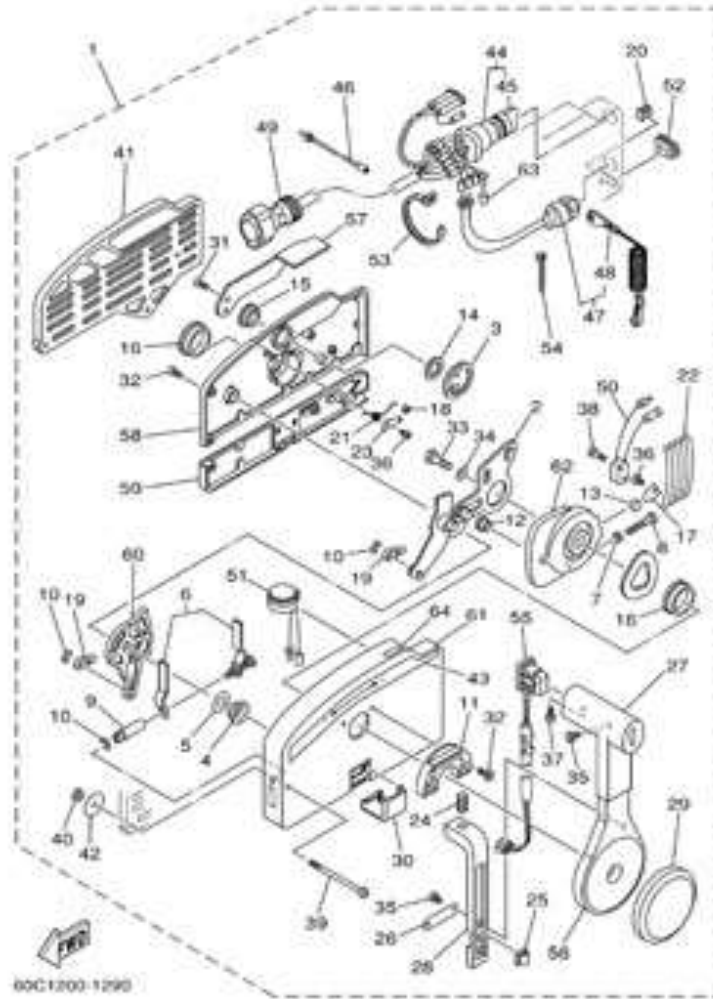

Before and after (library) photos 13/3/2018



It was a pig of a job. Everything covered in grease and springs, cams etc. dropping out. Eventually got it all back together and working.

Skylark Restoration



Boat re-wired except for dashboard 14/3/2018
Stripping old varnish off wheel 19/3/2018



Skylark Restoration



Floor panels, skirting and door step fitted 19/3/2018



Skylark Restoration



Trial fit of kit form seat & removed dashboard 21/3/2018

Stained seat fronts 21/3/2018



Skylark Restoration



Glass fibre applied and then painted inside of gas locker 22/3/2018

Final painted applied to seat kit 23/3/2018



Skylark Restoration



Restored boats wheel 22/3/2018
New dashboard 23/3/2018



Skylark Restoration



New dashboard and refurbished wheel fitted 24/3/2018



Skylark Restoration



Fitted seat/steps. Replaced gas pipe, Carbon Monoxide Alarm. 25/3/2018

Fitted Gas, Padded seat tops, Table clips and painted screw heads black. 26/3/2018



Skylark Restoration



Captain Chris happy with the modifications. 25/3/2018

End of phase one. 26/03/2018

Just need to get rid of the old floor and substructure before starting phase 2 !!



Skylark Restoration



Making stable style cabin door. 17/04/2018

Stable style door fitted complete with coloured window. 23/04/2018



Skylark Restoration



New cabin door and caravan style door lock and folding seat 23/04/2018
New seat folded away. Covered with the original rear seat vinyl. 24/04/2018



Skylark Restoration



Old hinge positions painted white. New lock strike plate fitted 25/04/2018
And now move to new mooring at High Offley



Skylark Restoration



Installing our own tyre fenders
New step and mooring post



Skylark Restoration



New storage box on decking built for pallets
Solar panel, Broadband Aerial installed and spot lamp moved



Skylark Restoration



New home made flat pack generator box (07/06/2018)

Generator box installed (07/06/2018)



Skylark Restoration



Starting the sanding down the cracked surfaces to repaint (July 2019)
Had to sand roof right back to original Orange Gelcoat.



Skylark Restoration



Continued sanding
Striping paint off the hard wood hand rails (July 2019)



Skylark Restoration



Had to strip out interior roof to gain access to Hand rail screws



Skylark Restoration



Removed all the leaking pop rivets and replaced with stainless steel nuts and bolts.
Replaced old Perspex window and polished aluminium frames. (September 2019)



Skylark Restoration



Painting progressing
Caroline helping while the weather holds (September 2019)



Skylark Restoration



Just when we decided not to remove boat from the water. We detected a leak.
A total strip out of the inside strengthening bar fitted ready for lifting out.



Skylark Restoration



Outboard prior to cleaning. (5th October 2019)

Outboard fitted to new maintenance stand ready for servicing (7th October 2019)



Skylark Restoration



Bob the land owner/farmer lifted the boat out with his digger. (31st October 2019)



Skylark Restoration



Had to scrape off all the shell fish (November 2019)
Jet washed the hull prior to sanding



Skylark Restoration



Had to cut through false floor and remove the ballast. Loose sand. (November 2019)
14 bags!



Skylark Restoration



Originally there had been plywood between fibreglass and sand but this had rotted completely.



Skylark Restoration



Four holes patched with fibreglass resin and matting (8th November 2019)
Two handrails completely stripped and re varnished (July 2019)



Skylark Restoration



All the Gunnel rubber removed and Wooden straking removed and screw holes filled.
Grey Anitfouling primer applied (January 2020)



Skylark Restoration



Hull primed and Gunnel stripped of sealant and loose paint (February 2020)



Skylark Restoration



Ready for two coats of white boat paint and three coats of antifouling (February 2020)



Skylark Restoration



Cutting tyres in half and chaining them to the bank over the Armco that is reinforcing the bank 23rd February 2020.

No leaks into the cabin!! I think I have found and sealed leaks around windows. Also drilled additional drain holes in sliding channels. Sanded and painted. First lot of dried sand!



Skylark Restoration



Diesel Air heater fitted below heat shield and deck.



Skylark Restoration



Ballast sand installed and covered with ply and then original fibre glass panels taped and glassed into place.

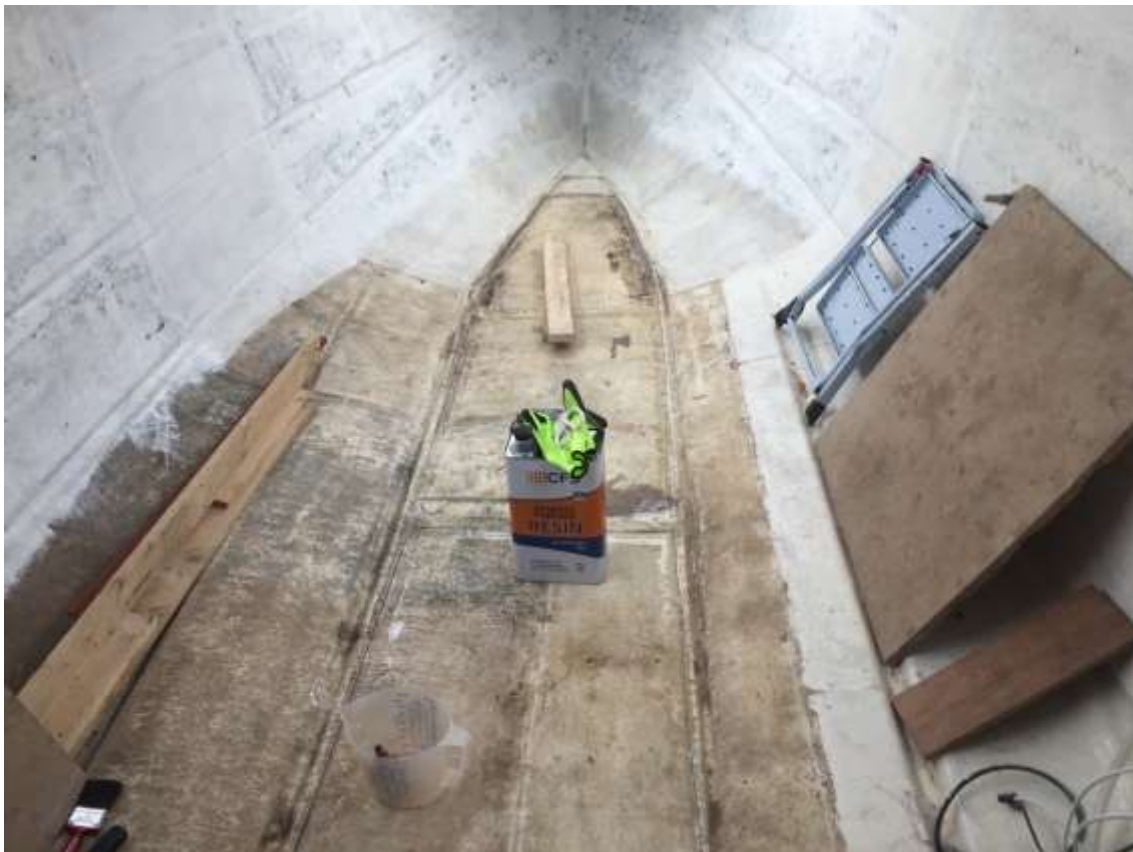

Skylark Restoration



Cut battens of 7/8" x 1 3/4" Mahogany for Gunwale. Stripped old varnish and sanded. Clamping blocks glued and screwed ready for bending gunwale battens.



Skylark Restoration



Mahogany batten placed inside layflat poly tubing and fed with steam from wallpaper stripper. Restricted steam flow out to ensure tubing inflated. Steamed for just over 1 hour.



Skylark Restoration



Batten whilst still in poly tube and being steamed clamped and bent to shape.
Example of straight on the left and bent on the right.



Skylark Restoration



Used new flywheel puller to remove flywheel. Changed timing belt, oil, plugs, fuel filter
(April 4th 2020)



Skylark Restoration



Removed bottom end to change worn out impeller



Skylark Restoration



Gear box oil changed. Note the corrosion! (April 5th 2020)
Corrosion treated and primed and finished with Honda silver paint



Skylark Restoration



Final test run on the maintenance rig. (April 2020)



Skylark Restoration



After cutting battens for rubbing strakes I made a jig to cut them into two pieces.
25/04/2020



Skylark Restoration



Replaced bilge floor leaving access to bilge pump.
Two new battery boxes. Main and Auxiliary Batteries. (26/04/2020)



Skylark Restoration



Removed deck fittings and filled holes (3/5/2020)
Sanding rubbing strakes (5/5/2020)



Skylark Restoration



Made new cleats from mahogany (6/5/2020)

Following steam bending strakes. Varnished gunwales, strakes and cleats (7/5/2020 to 15/5/2020)



Skylark Restoration



Fitted refurbished hand rails (17/5/2020)
Fitting Gunwales and rubbing strakes (18/5/2020)



Skylark Restoration



Masking up and painting anti-slip paint on decking (21/5/2020)



Skylark Restoration



Made and fitted temporary windscreen to enable refurb of old screen.
However decided to make replacement from mahogany (25/5/2020)



Skylark Restoration



Stern timber and cleats fitted.

With Caroline's help stripped paint off fenders and brackets (26/5/2020)



Skylark Restoration



Making new windscreen frame. Steam bent top piece. (1/6/2020)
Windscreen completed now designing side screens (11/6/2020)

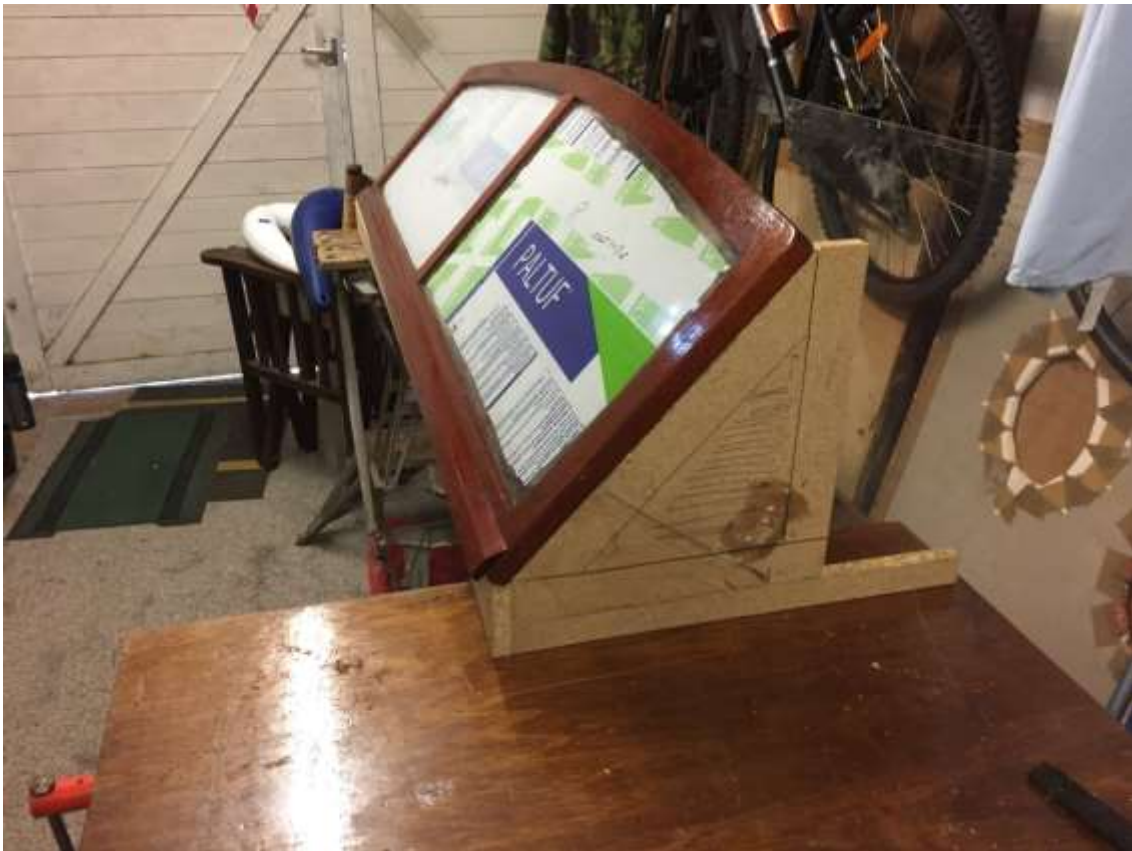

Skylark Restoration



Attached fenders with new ropes. Asked Bob to lift back into canal. (14/6/2020)

Applied new "Skylark" name. Checked no leaks in cabin. (17/6/2020)



Skylark Restoration



Day of the relaunch. Bob and his mate "Big Chris" (24/6/2020)
Bit scary! Glad I wasn't there. Ian, a neighbour, filmed and help out!



Skylark Restoration



Caroline restored cabin window with Brasso (22/6/2020)
Turned boat round and refitted outboard with Chris's help (26/6/2020)



Skylark Restoration



18mm plywood floor primed underneath & bonded to fibreglass (2/7/2020)
Whole floor area painted with grey primer (2/7/2020)



Skylark Restoration



Removed old windscreen frame, prepped and painted (6/7/2020)
Fitted new Mahogany folding screen. Quick release canopy bar (7/7/2020)



Skylark Restoration



First test trip since boat back into the water. New view through the windscreen (11/7/20)

Wiring clipped up. One of the jobs to obtain 4 year BSC! (21/7/2020)



Skylark Restoration



Trial fit for measurements of kitchen unit (21/7/2020)
Trial fit of new kitchen unit carcass (15/8/2020)



Skylark Restoration



Trial fit of prototype Sofabed (18/8/2020)
Kitchen unit prior to handles and shelf (24/8/20)



Skylark Restoration



Laying the vinyl flooring (24/8/20)

Trying to determine minimum size of Toilet closet (26/8/20)



Skylark Restoration



Installed Kitchen unit (24/08/20)

Sofa beds installed and cabin wall clad (04/09/20)



Skylark Restoration



Front battened & insulated and cladding started (05/09/20)
Hull side walls and knee insulated and battened (09-11/09/20)



Skylark Restoration



Cladding around the windows (09-11/09/20)
Cladding lower part. (16-18/09/20)



Skylark Restoration



Cladding Portside Bow (21/09/20)
Cladding Starboard bow (22/09/20)



Skylark Restoration



Fitting rubber trim to edges of wood (17/09/20)

Fitted and sealed to prevent condensation going behind cladding (17/09/20)



Skylark Restoration



Another 20 boards being painted in the garage (23/09/20)
Cladding the ceiling prior to re-wire (24/09/20)



Skylark Restoration



Cladding almost completed. Led lights fitted (26/09/20)
Cutting the memory foam mattress in to individual pieces (24/09/20)



Skylark Restoration



Cutting the material to fit foam (25/09/20)
Making the covers for the sofa bed (25-27/09/20)



Skylark Restoration



New cushions in the boat (27/09/20)
Ceiling cladding completed (08/10/20)



Skylark Restoration



WC frame work (19/10/20)
WC completed (20/10/20)



Skylark Restoration



Templating front beds (20/10/20)
Completed front beds (26/10/20)



Skylark Restoration



Cooler box cupboard (27/10/20)
Curtains fitted 29/10/20



Skylark Restoration



Corner and utility cupboards with curtain fronts (3/11/20)
Front bunks finished (7/11/20)



Skylark Restoration



Double bed, slats fitted complete with cloth covers (11/11/20)
Step with tool storage and drawer (12/11/20)



Skylark Restoration



T&G under the bow deck. (15/11/20)
Folding top fitted to cooker (28/11/20)



Skylark Restoration



Two 100W solar panels fitted (27/11/20)
Supplying new 105 AH leisure battery



Skylark Restoration



Tested outboard. No tell tale water coming out of "Pee Hole"! (5/12/20)
Thermostat changed as stuck open and cleaned out manifold "Pee Hole" outlet. (7/12/20)



Skylark Restoration



Picnic on board Skylark using table (17/12/2020)
Stephanie & Caroline on board (22/05/2021)



Skylark Restoration



Painted cockpit surround Teak coloured paint (30/06/2021)



Skylark Restoration



Cleaning the canopy by scrubbing using chemical and then jet washer (12/09/2021)



Skylark Restoration



Clean canopy with two coats of Fabsil back on the boat (22/09/2021)



Skylark Restoration



Woodwork and some upper hull paint work sanded down and re-varnished & painted (17/10/2021)